

The Department's many facilities are available for rental. The fees listed below are established for short-term rentals. For long-term rentals, the Commission will establish an appropriate fee. Long-term rentals for profit or non-profit use must be submitted in writing and be discussed with the Director of the Carrollton Parks, Recreation, and Cultural Arts Department. **The rates noted below are for Carroll County residents, students, or those working in Carroll County. Outside of Carroll County, personal or group reservation prices will be doubled. Call 770-832-1161 to book a facility or to request more information.**

ATHLETIC FIELDS

All athletic fields (day without lights) \$10 per hour
 All athletic fields (night with lights) \$20.00 per hour
 Field lining and dragging, \$20.00 each time

Sports fields and facilities are available for reservations and/or rent by individuals, groups or organizations. Outdoor ball fields are available to rent for private tournaments. Fees for tournaments are per field per day: 1 field-\$175 each, 2 fields-\$150 each, 3 fields-\$140 each, 4 fields \$130 each. Concessions will be supplied by CPRCAD. A deposit of 25% of the total rental contract must be paid when the contract is approved and booked.

GYMNASIUMS

Organizations having no charge, \$50.00 per hour
 Organizations having a charge, \$100.00 per hour
 Basketball/Volleyball scrimmages, \$20.00 per hour
 Basketball/Volleyball games, \$30.00 per hour

Gymnasiums are available for reservation and/or rental by individuals, groups or organizations. The availability of these facilities is limited and varies with the season. All of the gymnasiums with the exception of the East Carrollton Park Gym, are available to rent for private tournaments for \$175 per day. The East Carrollton Park Gym is \$300 a day for tournaments or \$100 per hour for non-athletic events. A special contract is required for private tournaments and non-athletic events.

TENNIS COURTS

Tennis courts will be reserved starting Friday at 9 a.m. for the following week on a first-come first-served basis. The courts may be scheduled beginning Monday at 9 a.m. for that week only. **No reservations will be issued for Saturdays or Sundays.** Tennis courts may be reserved for **One Hour Periods Only**, unless special arrangements have been made.

TENT RENTALS

Tents are 15'x15'. Within Carrollton City Limits, tents are \$75 for 1st tent and \$50 for an additional tent. Fee is \$100

per tent within Carroll County. We setup and take down tents.

MEETING ROOMS

The Department has many rooms available that may be reserved for a variety of functions such as club meetings, training sessions, showers, dinners, etc. Depending on the nature and purpose of the reserving party, rooms are made available at reasonable rental rates. Tables, chairs, PA systems, audio visual equipment, etc. may also be reserved.

Stallings Community Center, Lakeshore Center, and C.H. Lavender Recreation Center

Groups having no charge, \$12 per hour per room
 Groups having a charge/selling products, \$30 per hour per room
 Pilot Auditorium at Stallings Community Center
 \$25 per hour to general public
 \$25 per hour to non-profit group
 \$30 per hour to non-profit group selling tickets, products
 \$40 per hour to for-profit group or business
 Civic Clubs and other organizations should call about special rates.

Carrollton Cultural Arts Center

Classrooms - Organizations/public having no charge, \$25 per hour
 Organizations/public charging/selling items, \$50 per hour
 Lobby - \$50 an hour (a minimum of four hours)
 Theatre/Stage - Call (770) 832-1161 for rental rates

W.P.A. CENTER RECEPTION HALL

This Center rents for \$50 per hour or you can book 8 hours for \$300. A \$75 refundable damage deposit must be paid at the time of booking. The hall has two beautiful stone walls, one of which contains a gas fireplace. Round and rectangular tables plus padded chairs are provided. For more information or to setup an appointment to view the building, call 770-832-1161.

OUTDOOR PAVILIONS

Outdoor pavilions are available to the public at Lakeshore Park, East Carrollton Park, Longview Park, Fire Station 24 for \$10 per hour. Picnic tables, benches, water, electricity, and restrooms are provided at most sites. The pavilions may be reserved by families or groups for outings.

LAKE CARROLL INFORMATION

WATER CRAFT PERMITS - It shall be unlawful for any person to operate a watercraft on Lake Carroll without obtaining a permit. Permits are issued by the Carrollton Parks, Recreation, and Cultural Arts Department. Call (770) 832-1161 for a permit application. A watercraft permit will expire on December 31 of the current year. Boating permit fees are as follows:

Carrollton City Residents (Any person having real estate on the City Tax Digest) - Boating (skiing, fishing, etc.) \$50; Personal Watercraft (jet skis, jet boats, etc.) \$50; Non fuel powered watercraft (electric trolling motors, kayaks, canoes, john boats, etc.) \$15; Pontoon Boats \$50; Business & Commercial \$50.

Non-Resident Boating Permit - (Must show State Boat Registration & the owner's driver's license) Boating \$150; Boating (3-day permit) \$10 per day (3-day permits can only be purchased by persons living outside the Carroll County limits); Business (personal jet ski boat, etc.) \$65.

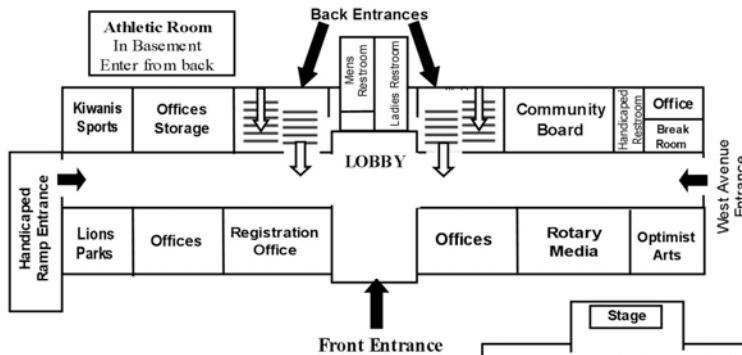

**Dr. Tracy P. Stallings
Community Center
118 South White Street**

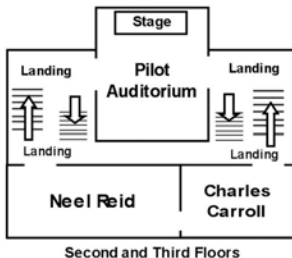

FIRST FLOOR ROOMS

Optimist Arts - 484 sq. ft. (22' x 22') All setups can be for 36.

Community Board - 682 sq. ft. (22' x 31') This room offers a conference table with comfortable seating for 16. There is also a smaller antique table for use. Additional chairs/tables can be placed against the walls.

Kiwanis Sports – 682 sq. ft. (22' x 31')

Lions Parks – 528 sq. ft. (24' x 22')

Rotary Media – 704 sq. ft. (32' x 22')

Seating for 30-40 is provided including chairs and tables for the Kiwanis/Lions rooms and seating for 50 in the Rotary room.

SECOND FLOOR

Pilot Auditorium - The main floor of the auditorium is 2444 sq. ft. and will seat an audience of 225. Our 26' x 14' stage has wood flooring and a velvet curtain which can be left open or closed. The Public Address system, lights, and room setup are included in the fee.

THIRD FLOOR Neel Reid - 1333 sq. ft. (43'x31') Setups for up to 75.

Charles Carroll - 889 sq. ft. (29'x31') All setups can be for 50.

**Bonner Recreation Center
226 West Avenue**

The Center is located behind the Stallings Community Center at 226 West Avenue and houses a regulation sized gymnasium, boxing room, fitness workout room and aerobics room. The gymnasium is used for Wrestling and Indoor Soccer games, and as well as some Martial Arts Classes.

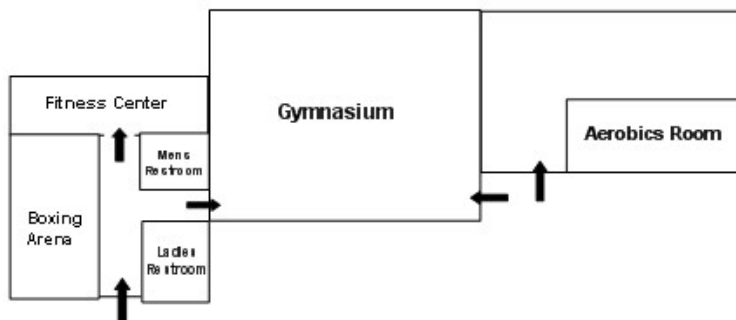

**Carrollton Senior Center
220 West Avenue**

The Carrollton Senior Center is open daily, Monday through Friday. Each day at noon, lunch is served to members at a cost of \$2.00 for ages 60 and better, \$3.50 ages 55 to 59. You must sign up for lunch by 10:30 a.m. each day.

An annual fee of \$10 is required and covers all programs unless noted otherwise. You can pick up a copy of the monthly activity calendar at the Carrollton Senior Center.

Please contact our Site Manager, Danielle Jenkins, at (770) 832-1644, if you have any questions.

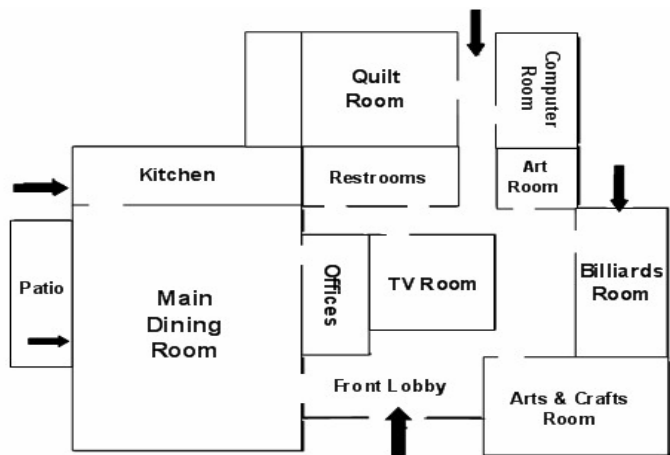

**Midtown Water Park
25 Leroy Childs Drive**

The Midtown Water Park is located on the corner of Leroy Childs Drive and Alabama Street and is open for summer fun only. The park features Kiddie Slides, a 150 foot Spiral Speed Slide, Zero Depth Water Area for younger children, a Rain Tree, Walrus Swings, Concessions, picnic area and much more.

When the pool opens for the Summer, our regular open swimming hours are from Noon to 5 p.m. Monday through Saturday and 1 p.m. to 5 p.m. on Sundays. Private 1½ hour parties may be reserved for 20 or less swimmers, up to 125 swimmers. The rental times and fees are noted in the Aquatics section of this book. Call 770-832-1161 to make your reservation.

Carrollton Cultural Arts Center
251 Alabama St.

The 40,000 square foot facility has a 262 seat theatre, 1365 square foot Art Gallery for exhibitions, a Galleria for our permanent art collection, Theatre Rehearsal Hall, dressing and costume rooms, a scene shop, Choral Rehearsal room with built-in risers and sound absorbers, and an educational wing with four classrooms and a kiln room.

The Theatre has wheel chair seating at the front and center of the theatre to allow patrons a choice of seating. The entire facility is accessible for wheelchairs.

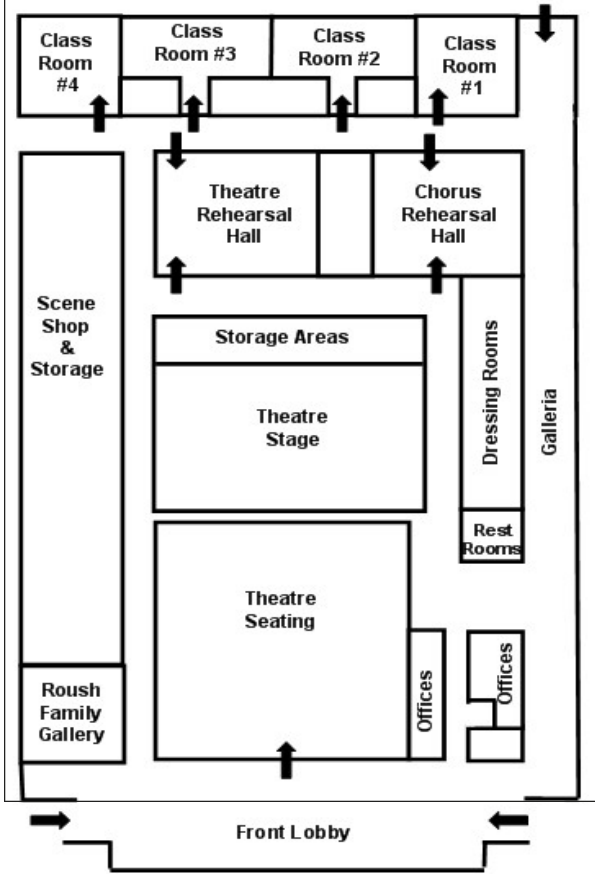

East Carrollton Recreation Complex
410 Northlake Drive

This center offers a Gymnastics Center, two Basketball Gymnasiums with bleachers and the Cheer Zone. The colorful and spacious lobby has room to sit or stand between events or while waiting for a class to be finished. For special events, we will open the concession stand.

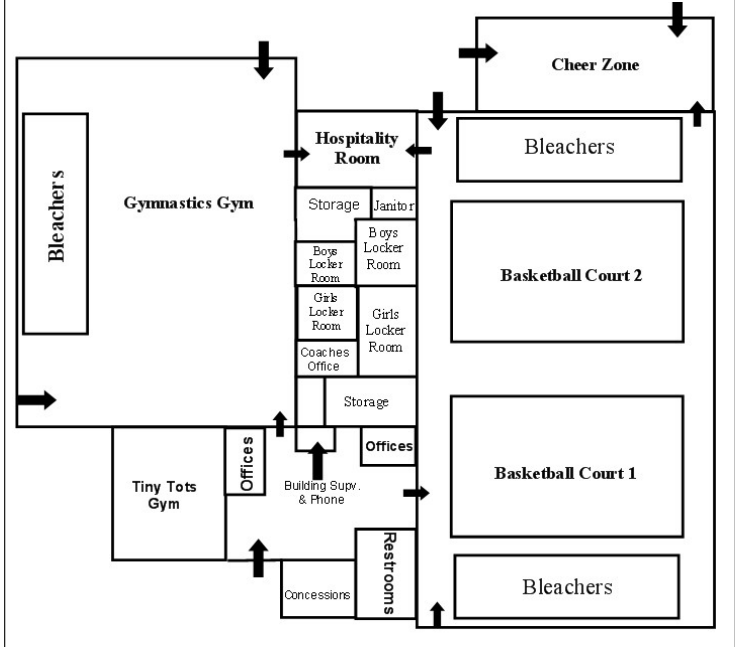

Lakeshore Recreation Center and Natatorium
643 N. Lakeshore Drive

Across the road from beautiful Lake Carroll, you will find the Lakeshore Recreation Center. The Center houses a regulation size gymnasium and various rooms and offices. In addition, the indoor Aquatic Center, the Lakeshore Natatorium, is located next to the Center where we offer Swim America swimming lessons for all ages and abilities. You will find many programs available such as Water Aerobics, Masters Swimming, lap swimming, and free swim. American Red Cross courses and CPR for the Professional Rescuer are offered in this center.

The Carrollton Bluefin Swim Team holds practices and hosts swim meets here at the Natatorium.

Private Pool rentals may be made for Saturday and Sunday evenings. You will also find a track, 6 tennis courts, and 4 ball fields.

A covered picnic pavilion which seats 100 and has a small playground is located in front of the center.

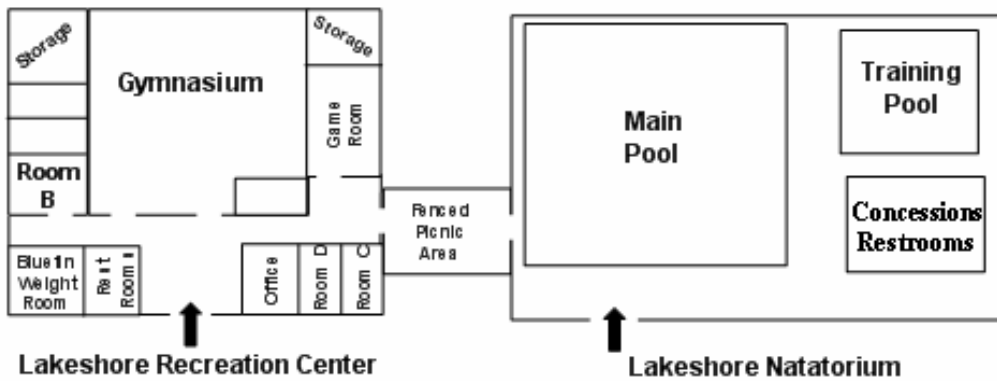

*WPA Center
590 North Cliff Street*

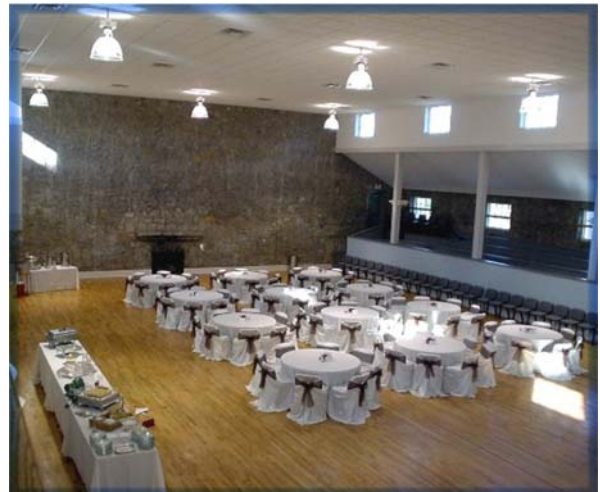
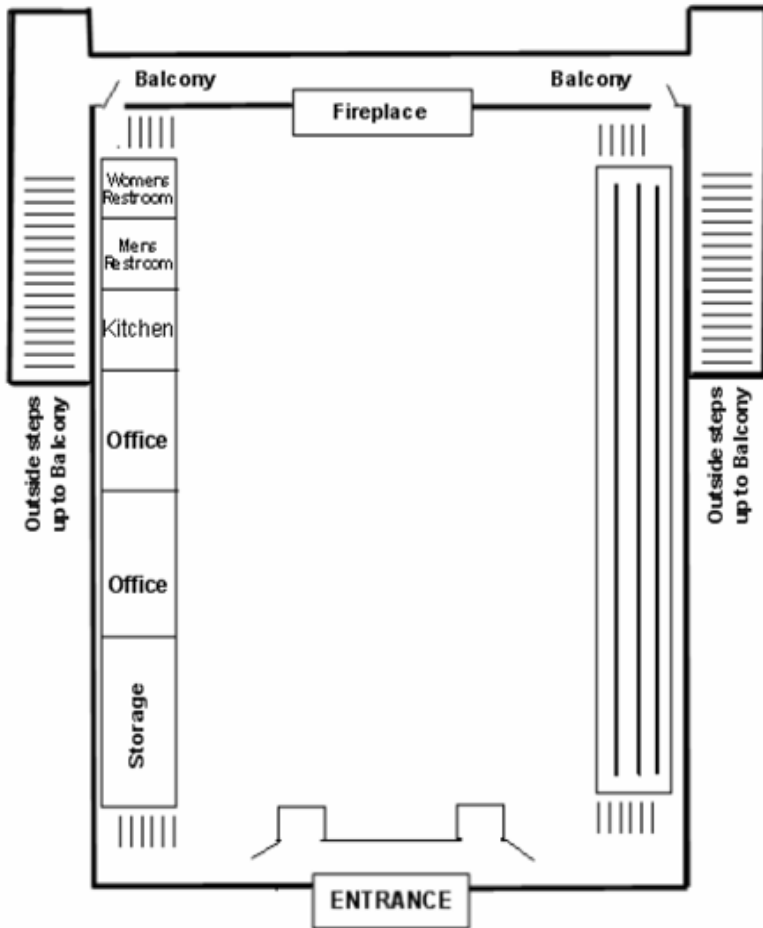

The WPA Center was built in 1936 by the Works Progress Administration, a relief measure established in 1935 by President Franklin D. Roosevelt. The W.P.A. created employment for 8,500,000 different persons on 1,410,000 individual projects, and spent about \$11 billion during its 8 year history.

The WPA Center was referred to as "The City Gym", home of the Carrollton "Flexettes" Gymnastics Team until late 2001 and many recreation programs.

There are now three staff offices in the building and a 42'x26' Reception Hall with a gas log fireplace. Banquet capacity is 164, Meeting capacity is 200, plus there is extra seating for 50 in the original bleachers on one side of the hall.



*Catherine Hardy Lavender
Recreation Center*

The Catherine Hardy Lavender Recreation Center is a multi-purpose complex consisting of a gymnasium, four classrooms, computer lab and an adult health & wellness center.

Located nearby is a regulation baseball field and the Optimist park is nearby.

